

SITING EVALUATIONS FOR THE IGNITOR FUSION EXPERIMENT: PRELIMINARY RADIOLOGICAL ASSESSMENTS

M. Zucchetti, L. Bonavigo, F. Franza
DENER – Politecnico di Torino
Corso Duca degli Abruzzi 24, I-10129 Torino, Italy
massimo.zucchetti@polito.it

M. Caldarella, F. Chiaravalli, F. Mancini, G. Faelli*
Sogin, Società Gestione Impianti Nucleari, Roma, Italy
* retired

A. Ciampichetti
ENEA FPN FIS ING, CR Brasimone
I-40032 Camugnano (Bo), Italy

F. Bombarda
ENEA CRE, 00044 Frascati (Roma), Italy

B. Coppi
MIT, Cambridge, MA 02139, USA

Abstract— Ignitor is a compact high-magnetic field machine aimed at studying plasma burn conditions in Deuterium-Tritium plasmas. The Caorso Site, in northern Italy where a nuclear power reactor had operated, has been selected as the most appropriate site for the operation of the Ignitor machine in view of all the facilities that are in place and of its connections to the electric power grid. Preliminary Radiological Impact analyses connected with the siting of Ignitor at Caorso are presented. The relevant radiological impact turns out to be negligible both during normal operation and in case of accident.

Keywords - Ignitor, siting, radiological impact, Caorso site, accidental analysis

I. INTRODUCTION

Ignitor is a compact high-magnetic field machine aimed at studying plasma burning conditions in Deuterium-Tritium plasmas [1]. The total radioactive inventory at end-of-life irradiation has been estimated in about 10^{17} Bq of activation products at shutdown, about $6.8 \cdot 10^{15}$ Bq after 1 week, $3.3 \cdot 10^{14}$ Bq after 1 year, 10^{12} Bq after 50 years of decay. The tritium inventory in the whole machine, including the fuel system, amounts to a few grams. The core of the Ignitor machine is shown in Figure 1. The dimensions of the machine are compact as Ignitor has a major radius of 1.3 m, minor radii of 0.47 m and 0.87 m. At ignition it will have a peak plasma temperature of about 12 keV, a peak plasma density of about 10^{21} ions/m³, at a maximum fusion power of about 90 MW.

Figure 1 Core of the Ignitor Machine

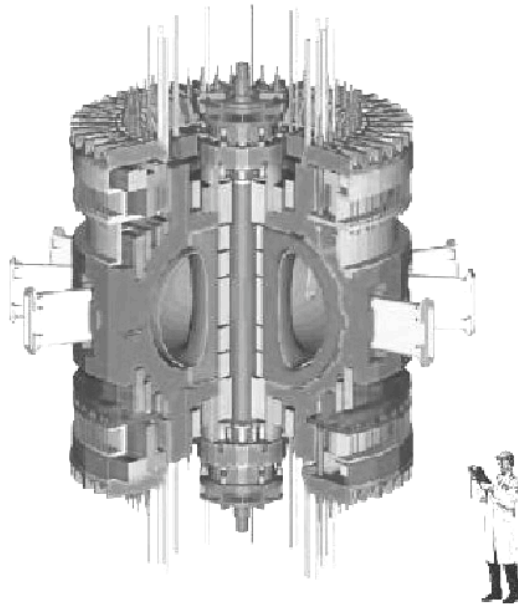

Pulses at different power levels are planned, with either DD or DT operation. The tokamak main components are: a molybdenum first wall (volume: 2 m^3), an INCONEL625 vacuum vessel (4.4 m^3), the Cu-based toroidal magnets (12.2 m^3), and the AISI316 machine structure (named "C-Clamp", 24 m^3).

The Ignitor experimental reactor operation lifetime will be divided into two phases: in the second one, tritium and neutron activated materials will be present, however quite moderately. Ignitor has a scheduled activity running for ten years. After a first period with aneutronic plasmas (H and He), useful for the setup for the machine, a second period with DD plasmas will follow. After this, starting from the third year, DT discharges will begin: tritium concentration will grow from an initial 5% to 50% (at the beginning of the fourth year) and plasma power will increase. Maximum, i.e., machine end-of-life, irradiation (ten years) is considered. Total operation time of Ignitor is quite small. In fact, after a discharge of about 4 s, pauses last for hours. In total, during the ten-years life of the machine, about 9000 s of DD plasmas and 6000 s of DT plasmas are scheduled, with also about 9000 s of aneutronic plasmas.

The machine has very low radiological risks and environmental impact. However, most of the accident source terms that impact the environment come from the tritium inventory.

II. THE CAORSO NUCLEAR SITE

Localisation of this experiment in Italy has seen growing attention during the last years [2]. The determination to carry out this project in Italy has driven to taking into account several candidate sites. Recently, due to several technical reasons, it was identified a new site, the Caorso Site, in northern Italy, a nuclear site where a nuclear power reactor was sited. The power reactor is presently under the decommissioning phase, and the site could be easily utilised for Ignitor siting and operation. The actual cost of building a new experiment can be considerably contained if infrastructures are already available on its envisioned site. The facilities of the Caorso site (near Piacenza, Italy), have been analyzed in view of their utilization for the operation of the Ignitor machine. The main feature of the site is its

robust connection to the electrical national power grid that can take the disturbance caused by Ignitor discharges with the highest magnetic fields and plasma currents. Other assets include a vast building that can house the machine core and the associated diagnostic systems with modest modifications.

Caorso is a nuclear site, so many data were collected over the years and are available [3]. These informations regard wind velocity and direction, the atmospheric stability classes for different weather conditions, and population distribution and food consumption habits around the site.

Preliminary Radiological Impact analyses for the siting of Ignitor in Caorso are presented in this paper.

The following goals must be obtained by the analysis:

- The Ignitor experiment must protect the health and safety of the facility personnel and of the public, by maintaining an effective defence against hazards,
- Ignitor must maintain an operation that is environmentally acceptable to present and future generations, and to satisfy the two basic requirements for environmental feasibility of fusion:
 1. No need of public evacuation in case of the worst accident
 2. No production of waste that could be a burden for future generations, i.e., minimisation of the production of long-lived radwaste

The question of waste has been addressed in previous papers [4]. Some of the remaining questions will be discussed here.

III. ENVIRONMENTAL RELEASES DURING NORMAL OPERATION AND ACCIDENTS

Environmental releases during normal operation for Ignitor are practically negligible, and deal with quite small quantities of tritium.

Early evaluations of those releases were performed in past assessments [5], and arrived to the determination of a total annual release of about 30 Ci of tritium in gaseous form.

Those assessments have been updated and reduced in quantity, due to recent revisions in the machine tritium system [6], operation schedule, characteristics, etc. According to those last updates and revisions, the routinely released quantities from Ignitor are reduced to almost nothing, being estimated to be inferior to 1 Ci per year. To be on a safe side, the annual quantity of 1 Ci of tritium will be considered for the annual routine releases.

Concerning accidents, the non-site dependent accidental analysis of the machine has been recently completely reevaluated [7]. For instance, as mentioned, a new design of the machine Tritium System (TRT) has been necessary, in order to cope with the recent evolutions of the machine design [6].

Main implications for safety dealt with the necessary recalculation of the tritium inventory. The new design has brought to a reduction of the tritium inventory in Ignitor

As a consequence of modifications to TRT and tritium inventory reduction, many of the environmental source terms considered in previous accidental analyses have been reduced.

Also, the probabilistic safety assessment upon which the accidental analysis is based has been reviewed considering new and better data, and accidental sequences frequencies redefined.

Probabilistic Safety Assessment main phases may be summarized as follows:

1. System functional analysis
2. Failure Mode and Effect Analysis (FMEA)
3. Identification of the Initiating Events
4. Classification of the Initiating Events
5. Analysis of the accidental sequences (probabilistic and deterministic) with Event Tree and Fault Tree techniques
6. Determination of the release source terms and frequencies
7. Evaluation of doses to personnel and to public (MEI = Most Exposed Individual)

The FMEA has analyzed the following systems:

1. Machine structure
2. Magnet system
3. Cryogenic system
4. Vacuum system
5. Gas injection system
6. Tritium system

The probabilistic safety assessment upon which the accidental analysis is based has been reviewed considering new and better data, and accidental sequences frequencies redefined.

Seven main accidental sequences groups have been finally identified. Accidental sequences defined as DBA (Design Basis Accidents) have been accounted for, having a frequency of $10^{-7}/y$ or superior.

Beyond DBA (BDBA) accidents have been initially considered in the evaluation, but their inclusion goes beyond the scopes of the radiological impact assessment of an experimental machine working for 6000 seconds with DT during all its lifetime.

A list of selected accidental sequences and a brief description is given in the following. For the sake of understandability, the same denomination as in ref. [8] has been kept.

I4 Failure of passing pipe in EX 1103 room

The fortuitous impact with moving members (hand-cars) that causes failure on line in external room at every containment, during gas transfer from TRT system to machine room, foreseen the gas discharge from pipe-line and could lead to fire ignition. If room has not appropriate containment systems, a tritium release to the environment could follow.

I5 Failure of GIS pipe in bunker

The failure of a GIS (Gas Injection System) pipe and consequent LOVA (Loss of Vacuum Accident) during plasma discharge, foreseen the possibility of air re-entry in the line, that reacts with gas causing combustion. Moreover machine losses vacuum condition and plasma disrupts.

Failure of pipe can be considered equivalent to Vacuum Vessel perforation, so in this case it supposes the 10% loss of radio-active material presents in VV.

I7 Loss of secondary containment in the Glove Box

The loss of secondary containment in the Glove Box, caused by structure failure or glove perforation, can bring undesired inert gas emission and probable air inlet to the box. The outlet of inert gas from Glove Box not implies remarkable risks because primary containment is integral. The air inlet in Glove Box is more risky because a fire can takes place in Nitrogen recombiner, due to its high working temperature (600-700 °C).

I11 Erroneous opening of the high pressure tank valve and unsuccessful release from LPT PSV to stack

The erroneous opening of the high pressure tank (HPT) valve and unsuccessful release from LPT (Low Pressure Tank) pressure safety valve (PSV) during gas removing and treatment period, foresees the possibility of LPT pressurization. The LPT is a container utilized to maintain gas manifolds at low pression, limiting overpressure risk.

I13 Short circuit on poloidal magnet adjacent at transformer central element

The short circuit on poloidal magnet adjacent at the transformer central element, during plasma magnetic confinement, foresees the formation of an electric arc with energy dissipation and active metallic compounds vaporization. To mitigate the electric arc effect, Energy Dumping System (EDS) is

utilized to discharge the energy on an external resistive load. In case of its unsuccessful intervention, the damage caused by energy dissipation can induce press shaft weakening with a possible failure and consequent missiles launching; missiles launching can cause the secondary containment failure. Activated materials remain into the third containment (liner), only in case of abnormal intervention of the ACS and ADS they could be released to the atmosphere.

Table I and II report the final selected environmental sequences, their frequency and environmental release quantity and quality. The radiological impact assessment will be performed for the off-site release sequences (Table II).

TABLE I – DBA ACCIDENTAL SEQUENCES, NO OFF-SITE RELEASE

	Frequency [ev/y]	Release (Ci)	Release (Bq)	Nuclides	Site
I7	9.66 E-6	0.02	5.8 E+8	T	Tritium room
I11	1.26 E-5	232	8.6 E+12	T	Glove Box
I13	3.87 E-6	100 136.1 130.2 22.6 7.9 5.1 1.9 1.7	3.7 E+12 5.036 E+12 4.817 E+12 8.362 E+11 2.923 E+11 1.887 E+11 7.03 E+10 6.29 E+10	T Mo99 Tc99m Cu64 Ag110 Cu66 Cu62 N16	Liner

TABLE II – DBA ACCIDENTAL SEQUENCES WITH OFF-SITE ENVIRONMENTAL RELEASE

	Frequency [ev/y]	Release (Ci)	Release (Bq)	Nuclides
I4	1.4 E-6	2.2	8.06 E+10	T
I5	1.76 E-6	151	0.56 E+13	T
I7	5.01 E-5	0.009	3.13 E+8	T
I11	8.50 E-3	142	5.24 E+12	T

Concerning dose evaluations for personnel and public, the GENII-FRAMES population dose code has been used [9].

The radiological impact assessment has been evaluated for normal operation and the results are shown in the following Table III. Releases are through the stack, of 60 meters of height, that is the available stack at Caorso site. The doses are trivial (nanoSieverts per annum).

TABLE III – RADIOLOGICAL IMPACT ASSESSMENT DURING NORMAL OPERATION

Population group	Adult, countryman	Adult, urban	Children, countryman	Children, urban
Equivalent dose Effective (microSv/y)	1,31E-03	1,26E-03	1,25E-03	1,21E-03

If no credit is given to the presence of the stack, considering then a ground release, the dose due to normal operation release is still trivial, i.e., $1,93 \cdot 10^{-2} \mu\text{Sv/y}$ for the adults, countryman (maximum value).

Some of the preliminary results of the assessments of population doses for off-site environmental release accidents are shown in the following table. In that case, to be conservative, ground releases have been considered, giving no credit to the availability of the stack. That is maximizing the doses. Exposure pathways are external irradiation, inhalation and ingestion: no credit to emergency measures of any kind is given (no evacuation, no food chain prohibition, no sheltering).

TABLE IV – RADIOLOGICAL IMPACT, DBA ACCIDENTS

Table IV.1 – EDE to the MEI, adults, countrymen, DBA

	Release (Ci)	Nuclide	Equivalent Dose Effective (Sv)	
			(Inhal+ext.irrad.)	(Inhal+ext.irrad.+ing)
I4	2.2	T	8,67E-07	1,20E-05
I5	151	T	5,95E-05	8,23E-04
I7	0.009	T	3,55E-09	4,90E-08
I11	142	T	5,59E-05	7,74E-04

Table IV.2 – EDE to the MEI, children, countrymen, DBA

	Release (Ci)	Nuclide	Equivalent Dose Effective (Sv)	
			(Inhal+ext.irrad.)	(Inhal+ext.irrad.+ing)
I4	2.2	T	1,12E-06	1,25E-05
I5	151	T	7,72E-05	8,55E-04
I7	0.009	T	4,60E-09	5,10E-08
I11	142	T	7,26E-05	8,04E-04

It can be noticed that the worst one among the accidental sequences defined as DBA (Design Basis Accidents) brings to a maximum dose for the MEI of the public of less than 1 mSv (0.25 mSv). This is lower than the annual dose limit for the public, and about one-tenth as a maximum than the average yearly natural background dose level. Such a dose does not imply people evacuation in case of accident, nor the adoption of any emergency countermeasure (sheltering, food prohibition, etc).

V. CONCLUSIONS

The radiological impact analysis for the normal operation and the main accidental sequences of Ignitor has achieved the following results:

1. The site of Caorso is completely characterized, both from the meteorological and population aspects, and it is fully apt to host the experiment.
2. The Ignitor machine, both during Routine functioning and DBA accidental sequences presents a negligible radiological impact. In fact:
 - The Routine Dose is as a maximum 0.0013 $\mu\text{Sv/y}$ with the stack, and 0.019 $\mu\text{Sv/y}$ without it. Those doses are by far trivial ones.
 - The Maximum Dose, in case of the worst accidental DBA sequence is 0.25 mSv, below any relevant limit for any emergency countermeasure.
3. As result of this analysis we can say that Ignitor machine does not need any further containment, such as a "concrete primary containment", like those used in nuclear power plants.
4. No need of people evacuation or any emergency countermeasure is necessary even in presence of the worst DBA accident.
5. As a further result, the presence of the stack for dispersion of airborne releases is not necessary from the radiological viewpoint.

REFERENCES

- [1] B. Coppi, A. Airoidi, F. Bombarda, et al., The Ignitor Experiment, Nuclear Fusion 41 (2001).1253-1268.
- [2] S. Migliori, F. Bombarda, S. Pierattini, G. Faelli, M. Zucchetti, B. Coppi, Installation of the Ignitor Machine at the Caorso Site, paper, DPP08 Meeting of The American Physical Society, November 17-21, 2008, Dallas, Texas (USA).
- [3] See website of the Caorso Nuclear Power Plant, at www.sogin.it
- [4] I. Antonaci, M. Zucchetti, A. Ciampichetti, Radioactive Waste Management And Safety For The Ignitor Fusion Experiment, Fus. Eng. Des. 75–79 (2005) 1237–1241.
- [5] M.Zucchetti, The Ignitor risk-based passive safety requirements, Fusion Technol., 30 (1996) 1501-1506.
- [6] C. Rizzello, S. Tosti, Overview of the tritium system of Ignitor, Fus. Eng. Des. 83 (2008) 594–600
- [7] M. Zucchetti, A. Ciampichetti, Safety and Radioactive Waste Management Aspects of the Ignitor Fusion Experiment, Fus. Sci. And Technol. (in print, 2009). Paper presented at the Topical Meeting on the Technology of Fusion Energy, S. Franscisco (US), october 2008.
- [8] A.Carpignano, S.Francabandiera, R.Vella, M.Zucchetti, Environmental impact analysis for the main accidental sequences of Ignitor, Fusion Technol., 30 (1996) 1490-1496..
- [9] The GENII-FRAMES code. See site <http://www.rsicc.ornl.gov>